

## TechNote #CM1 VIBCODE®

### Correct handling with the VIBCODE transducer

#### Brief description

VIBCODE is a transducer system which automatically identifies the measurement location. The VIBCODE transducer consists of an acceleration sensor for the acquisition of machine vibrations and high-frequency roller bearing signals as well as a coding ring sensor for the identification of the measurement location. Each VIBCODE measurement location is identified by a uniquely encoded plastic ring. The coding of the measurement location and programming of the measurement tasks are carried out in the OMNITREND PC software.

#### Measurement principle

The VIBCODE sensor locks firmly onto the VIBCODE measurement stud using a bayonet mounting. The code ring sensor then scans the tooth pattern of the plastic code ring to identify the measurement location. The programmed measurements are then carried out for this measurement location.

#### Advantage

Bayonet mounting:

Firm docking on the measurement location ensures optimum measurement orientation and consistent contact pressure. Consequently the results are reliable and reproducible.

Measurement location coding:

Measurement location mixup is impossible; Safe assignment of the measurement results in the database and repeatable trending.

#### Safety notes

- Only measure at VIBCODE measurement locations, not directly on the machine
- Ensure that the measurement location is not covered, coated with oil or contaminated with grease.
- Do not use silicon oil on the measurement location. If necessary, clean the measurement locations before measurement!
- Place the sensor UPRIGHT, press in lightly and fix with 1/4 clockwise rotation.
- Do not use force to plug in the sensor.
- Protection cap must not be jammed between the sensor and measurement stud.
- Place the protective caps on the measurement stud and VIBCODE sensor after use.

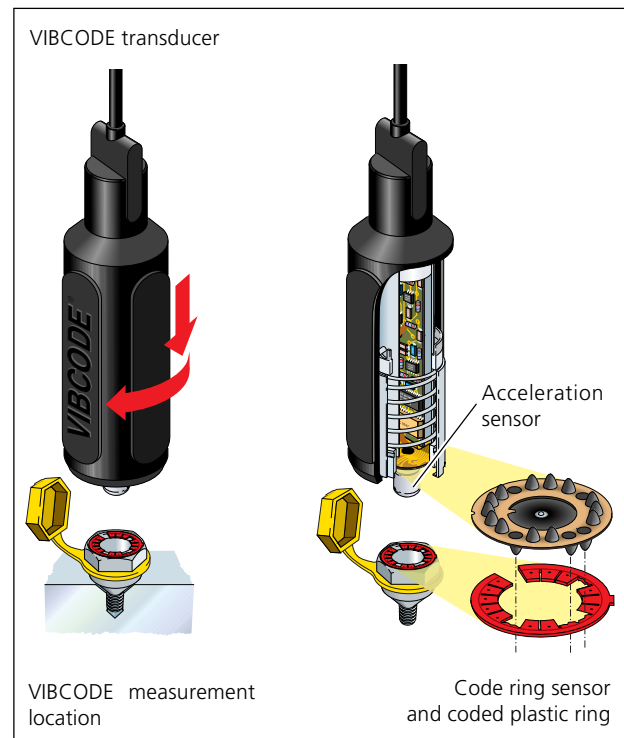

Connection and identification of the coded measurement location

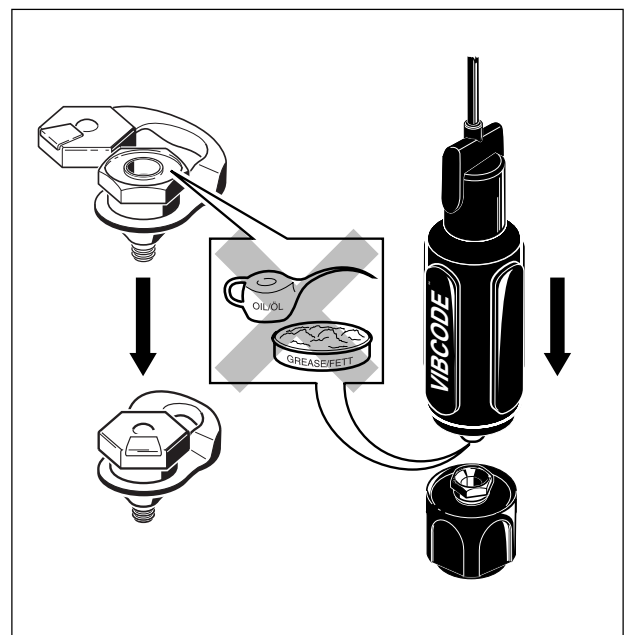

Protect measurement stud and sensor from dirt!

### Cleaning notes

- Wash off slight contamination of the sensor with soap solution or Isopropanol and cotton cloth.
- To avoid damage to sensitive components in the sensor head, clean with a brush.
- If compressed air is used for cleaning, only use a weak jet of air.

Never use a solvent!

Do not scratch off contamination using a screwdriver or other hard object!

### Did you know that ...

... VIBCODE can now also measure the vibration signals of low speed machines?  
VIBCODE sensors with serial numbers (SN) > 2500 have an extended frequency range (2Hz - 10KHz).

... a defective or damaged sensor head is easy to replace?  
Defective VIBCODE sensors (SN > 2500) no longer need to be sent to the manufacturer, but can be repaired at the local branch.

... non-codable measurement locations can be identified with VIBCODE?  
Simply attach a coded measurement stud near the actual measurement location - ready! First read the coding with VIBCODE and then measure with another sensor - e.g. temperature.

#### VIBROCORD:

The VIBCODE sensor is connected to channel A, measurement is carried out on channel B.

#### VIBSCANNER & VIBROTIP:

VIBCODE is connected to a measurement channel and can be detached after the instrument has identified the measurement location. Measurement is carried out using either an internal or external sensor.

Measurement with an external acceleration sensor with VIBROTIP is only possible if the VIBCODE measurement location number is greater than 6500.

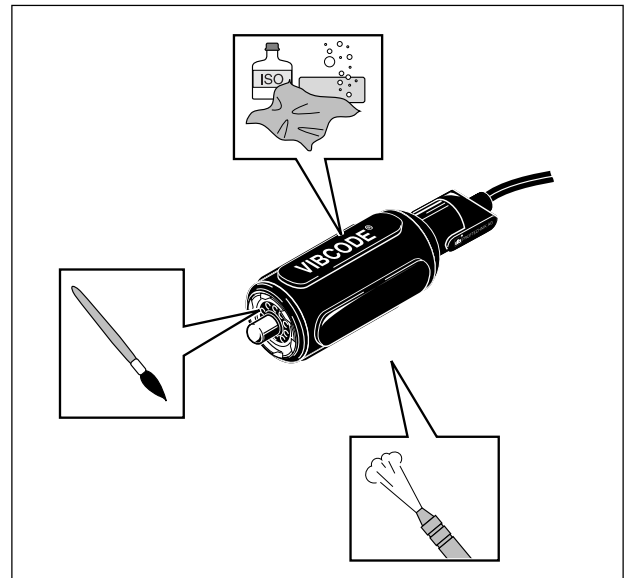

Cleaning

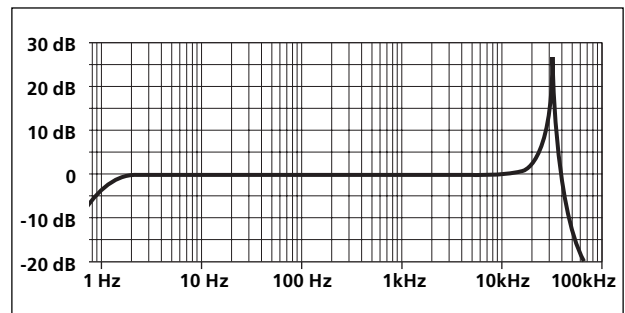

Frequency response

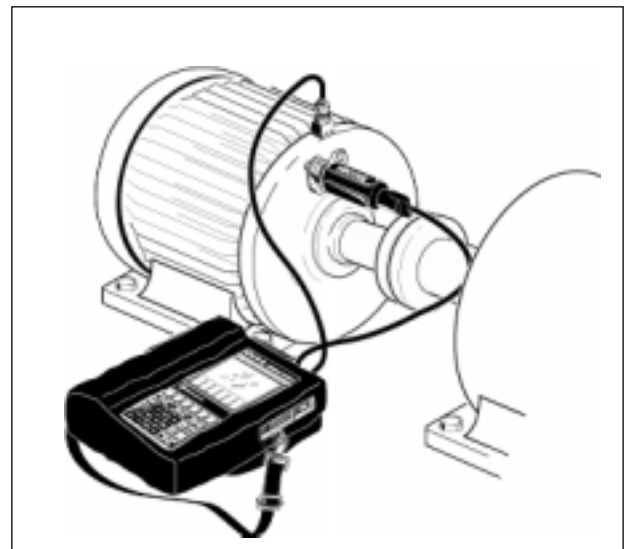

Identification of non-coded measurement locations

## Measurement studs for every application

A range of VIBCODE measurement studs are available in different versions\*, which can be adapted to the most varied local conditions:

\*UNC thread versions are also available.

### Standard measurement stud:

M8 thread, high-grade steel (VA1.4305)

Typical application:

All machines where a M8 thread with min. 14 mm hole depth can be drilled.

### Chemical-resistant standard measurement stud:

M8 thread, high-grade steel (VA1.4305)

Typical application:

As for the standard version, as well as in chemically aggressive industrial environments.

### Measurement stud with bonded mounting

Typical application:

Machine where no threaded mounting can be drilled:  
Motors in intrinsically safe areas, machines with thin bearing houses, ...

### Measurement stud with extension:

M8 thread, length 55 mm

M10 thread, length 95 mm

M12 thread, length 170 mm

Typical use:

Unexposed measurement locations where the standard measurement stud cannot be mounted directly (e.g. because of cowling).

### Measurement stud with lock nut:

Thread M8

Thread M10

Thread M12

Typical use:

Measurement locations which are covered by a cowling. The measurement studs can replace housing screws.

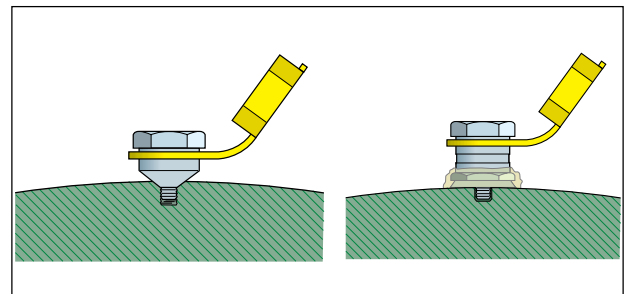

Standard

Bonded

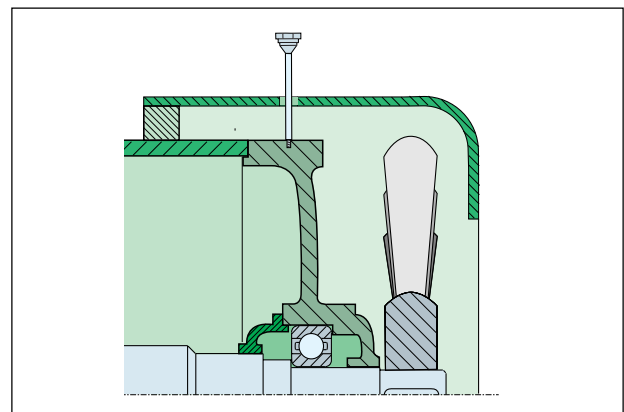

Extension

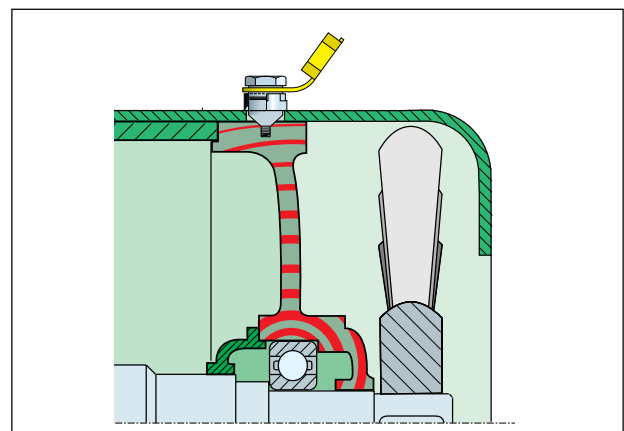

Lock nut