

PULLALIGN®

Accurate pulley alignment with laser



PULLALIGN® – the laser pulley alignment tool

Get more out of your belt driven systems by proper alignment

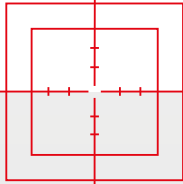

An aligned pulley system reduces pulley and belt wear, vibration of machinery, which in turn leads to improved machine performance. Good pulley alignment reduces unscheduled downtime, and improves the reliability of your equipment. PULLALIGN® is tailor-made for the job as it is easy to use, and requires only a single operator. The units mount onto virtually any pulley face, making it the ideal partner for most pulley alignment jobs. PULLALIGN® utilizes the proven and patented OPTALIGN® reflected beam principle for maximum angular resolution. This allows for accurate and reliable readings.

PULLALIGN® at work

A laser line is projected onto the reflector mounted on the opposite pulley. Horizontal angle, vertical angle and offset corrections are visually determined by the position of the laser line on both the laser and reflector. These alignment parameters are monitored simultaneously. Good alignment is achieved when the transmitted laser line and the corresponding reflected laser line harmonize with the respective reference line.

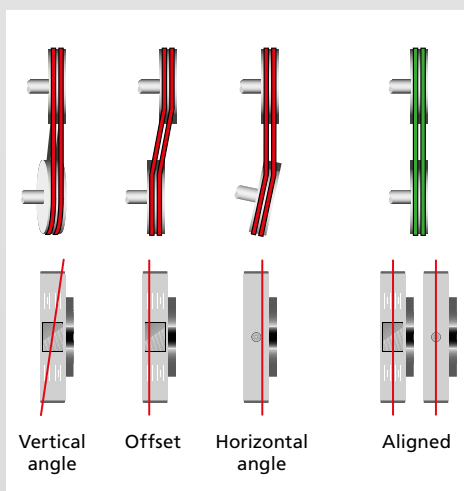

PULLALIGN® benefits

- ▶ Efficient one-man operation
- ▶ Shows offset, vertical and horizontal angle simultaneously
- ▶ Reflected beam technology doubles the distance, enhancing accuracy
- ▶ Only one laser for complete alignment
- ▶ Reduces down time and energy costs
- ▶ Reduces vibration and belt noise
- ▶ Prolongs belt, pulley and bearing life
- ▶ Time saving method as no cross-checking required
- ▶ Easier to use than conventional methods
- ▶ Supplied in a case or pouch
- ▶ No training required



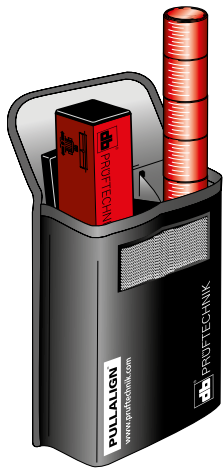

► PULLALIGN® Lite

The laser unit is magnetically mounted against the side of one of the pulleys and the three magnetic targets against the top, bottom and side of the opposite pulley. The laser beam strikes the three targets simultaneously. The alignment process involves moving one of the machines until the projected laser beam lies in the centerline of all three targets. This simple process is easily carried out with one operator.

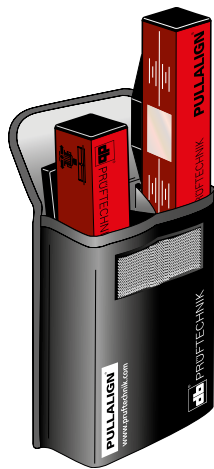
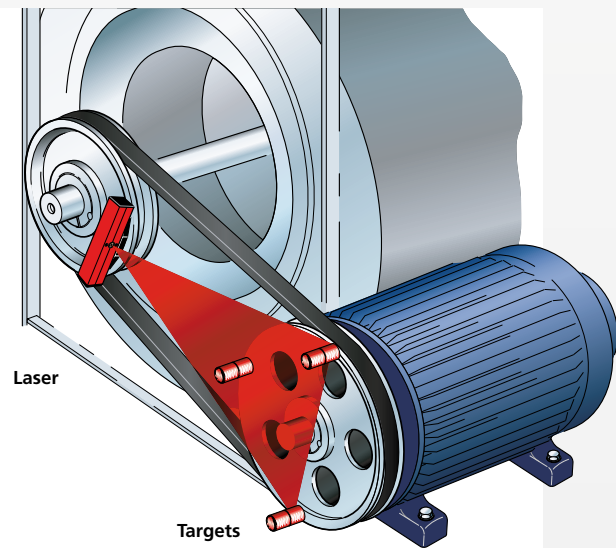

► PULLALIGN®

PULLALIGN® is a light, robust, rugged and durable system. Due to the powerful magnets of the laser and reflector, the tool mounts to the inside or outside faces of any pulley or sprocket drive. Its unique design ensures that there are no small parts that can get lost. The result is reliable and accurate readings that wire or straightedge alignment methods cannot match.



► PULLALIGN® Case

PULLALIGN® can measure long spans with any size pulley. This easy-to-use tool enables a single operator to complete the alignment in minutes without any training. PULLALIGN® comes in a durable case.



PULLALIGN® technical data

Laser	
Accuracy	0.2°
Laser wavelength	650 nm
Output power	< 1mW
Classification	Class 2M
Measuring distance	10 m between units
Laser line length	7 m at 5 m distance
Controls	Laser ON/OFF rocker switch
Battery type	4 AAA alkaline batteries
Operating time	25 hours
Operating temp	-5°C to 40°C
Storage temp	-10°C to 70°C
Mounting method	Strong magnets
Weight	0.26 kg (with batteries 0.3 kg)
Dimensions	37 x 40 x 170 mm
Housing	Aluminium, powder coated finish

Reflector	
Accuracy	0.2°
Reflector size	21 x 32 mm
Mounting method	Strong magnets
Weight	0.27 kg
Dimensions	37 x 40 x 170 mm
Housing	Aluminium, powder coated finish

Carrying case	
Material	Black, high density polyethylene
Dimensions	355 x 300 x 85 mm
Insert	Die-cut foam
Weight of package	1.35 kg

PRUFTECHNIK delivers maintenance solutions worldwide



Alignment Systems



Condition Monitoring



Nondestructive Testing



Service & Support

www.pruftechnik.com

PULLALIGN® is a registered trademark of PRUFTECHNIK Dieter Busch AG. No copying or reproduction of this information, in any form whatsoever, may be undertaken without express written permission of PRUFTECHNIK Dieter Busch AG. The information contained in this leaflet is subject to change without further notice due to the PRUFTECHNIK policy of continuous product development. PRUFTECHNIK products are subject to patents granted or pending throughout the world.
© Copyright 2017 by PRUFTECHNIK Dieter Busch AG.



PRUFTECHNIK Condition Monitoring GmbH
Oskar-Messter-Str. 19-21
85737 Ismaning, Germany
Tel.: +49 89 99616-0
Fax: +49 89 99616-200
info@pruftechnik.com
www.pruftechnik.com

- ▶ Made in Germany
- ▶ Global Presence
- ▶ Qualified Support
- ▶ Quality Service

A member of the PRUFTECHNIK group